

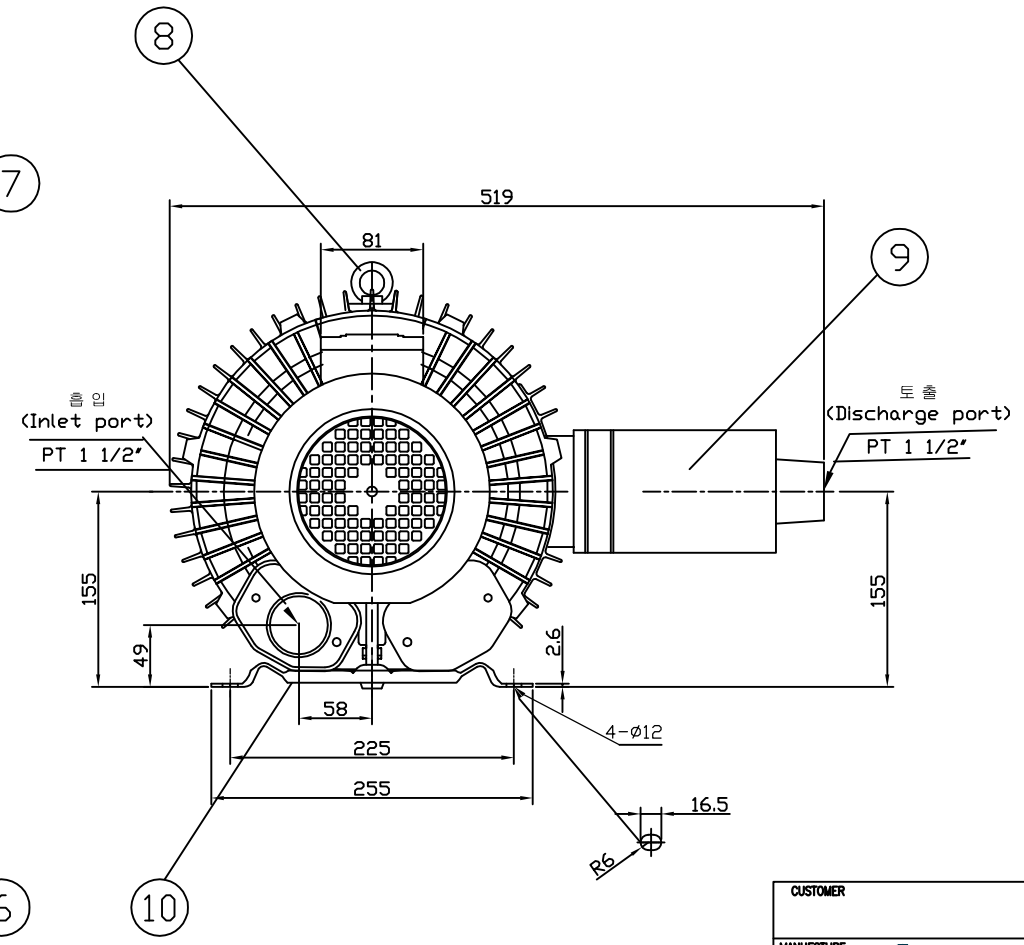

No.	Part Name	Material	Q'ty	Description
1	Case_1	AL	1	
2	Case_2	AL	1	
3	Heat exchanger	SS400	1	
4	Ring blade_1	AL	1	
5	Ring blade_2	AL	1	
6	Input port	AL	1	
7	Motor		1	
8	Lifting ring	SS400	1	
9	Discharge port	AL	1	
10	Installation B/K	SS400	1	

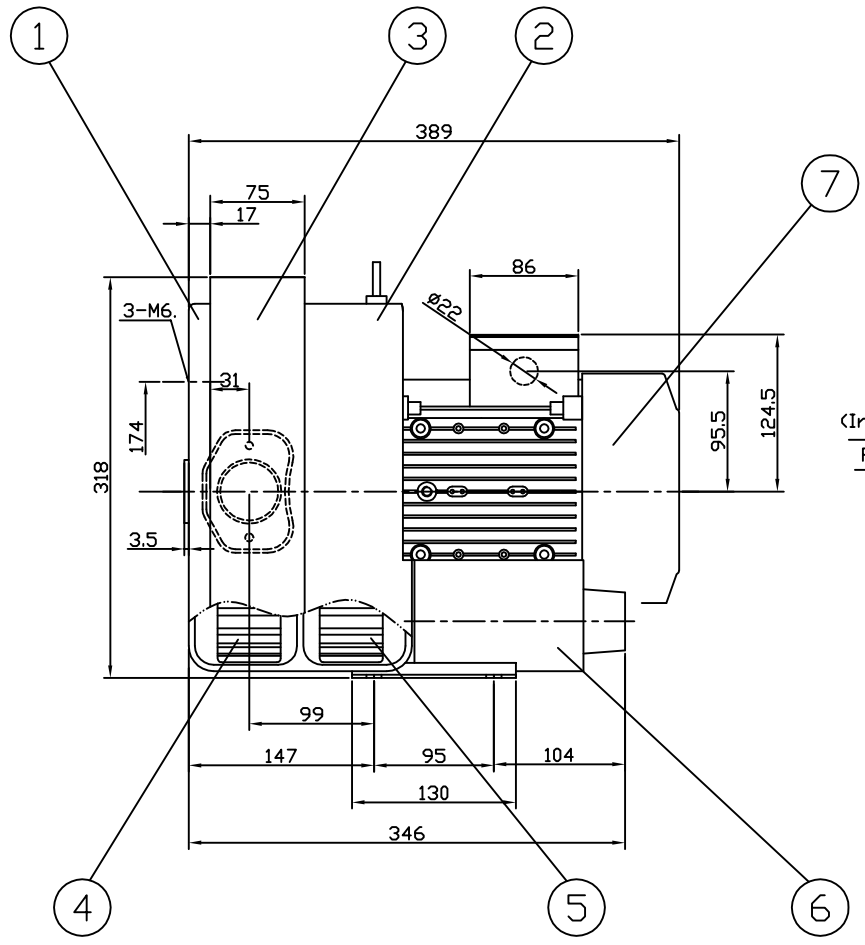

3φ1.75kw2p

CUSTOMER					
MANUFACTURE					
 (주)대하이엔지 DAEHA ENG Co., Ltd.					
TITLE <i>RING BLOWER(Reg. Blower)</i> DHB-402S					
CONTRACT DWG NO. 0402S003					
SCALE	PROJECT NO.	DRAWING NUMBER	MF-NO	TYPE	REV